

CAD FILE:

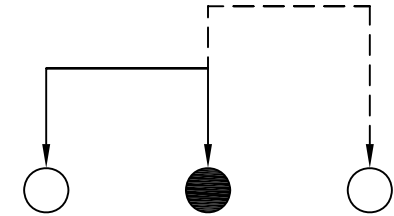

SCHEMATIC (NON-SHORTING)

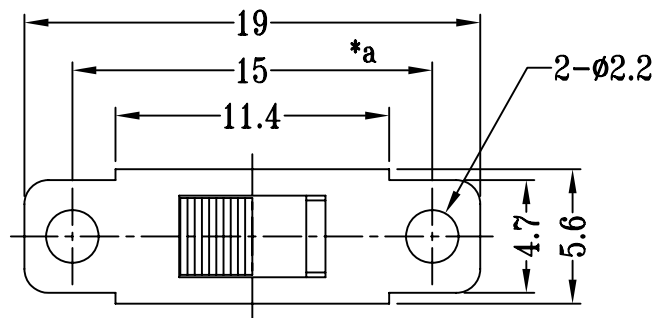
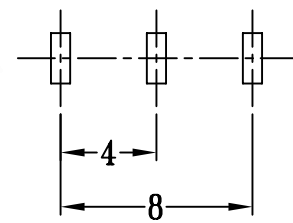
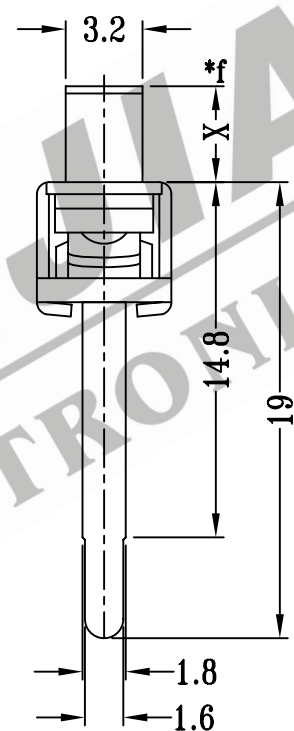
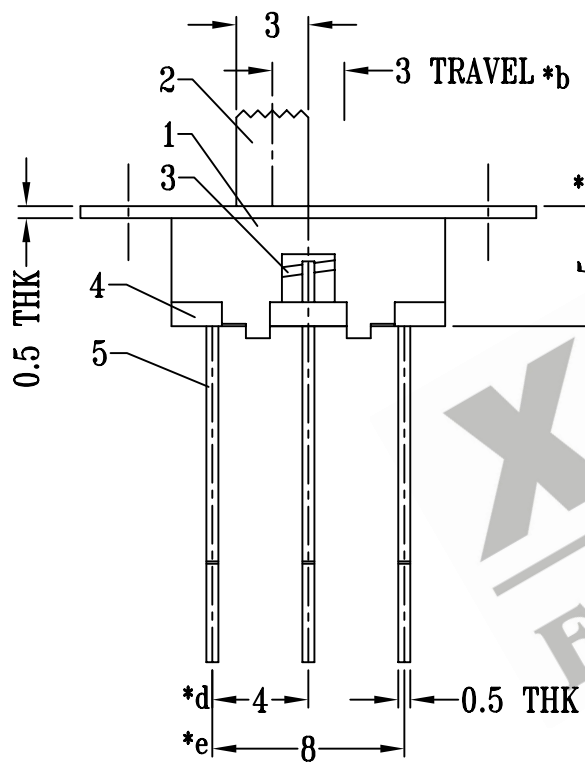

P.C.B LAYOUT

XIEJIA ELECTRONICS

注:带"*"表示关键尺寸(6个)

8					TOLERANCE UNLESS SPECIFIED	SHENZHEN XIEJIA ELECTRONICS CO.,LTD.				
7	SPRING	STEEL WIRE	1	TEMPER						
6	STEEL BALL	STEEL	1	NATURAL	WITHIN: 1.5±0.1mm	ISSUE	DATE	DESCRIPTIONS OF REVISION		APPD.
5	TERMINAL	BRASS STRIP	3	Ag PLATED OVER Ni PLATED	OVER : 1.5±0.2mm					
4	BASE	PHENOLIC RESIN	1	NATURAL	TITLE : VERTICAL SLIDE SWITCH		UNIT : mm	DRWG NO.: XJ-DR-SS12F73-00		
3	CONTACT CLIP	BRASS STRIP	1	Ag PLATED						
2	KNOB	POM	1	BLACK	MODEL: SS-12F73		SCALE: 3 : 1	DWN.	ZHOUYU	2002-9-16
1	FRAME	STEEL STRIP	1	BLACK				CHK'D	FANGYING	2002-9-16
NO.	PARTS	MATERIALS	Q'TY	FINISH	ALL MATERIALS MUST BE COMPLIANT TO ROHS			APPD.	KANGXINAN	2002-9-16